

DER, GUB and GUBM Cast Junction Boxes

Explosionproof, Dust-Ignitionproof, Watertight

Furnished with surface cover and mounting lugs.

CEC:

Class I, Division 1 and 2, Groups A, B, C, D

Class I, Zone 1 and 2

Class II, Division 1 and 2, Groups E, F, G

Class III, Enclosure 4

Applications

- Explosionproof and dust-ignitionproof for use in classified locations.
- Corrosion-resistant: ideal indoors or outdoors.
- Junction or pull box for pulling and splicing of wires and as an enclosure for electrical devices.
- Ideal where number and size of conductors require a junction box with additional space.

Features

- Provided with mounting lugs.
- Furnished with covers.
- All conduit hubs and openings provide a minimum of five full threads to meet CSA requirements.
- Accurately tapped, tapered conduit threads provide tight, rigid joints and ground continuity.
- DER and GUB Series
 - Wide selection of sizes and locations for drilled and tapped conduit openings.
 - Suitable for use as an enclosure for relays, instrument and other control apparatus in classified locations.
 - Available in high tensile strength malleable iron or copperfree aluminum bodies.
- GUBM Series (Instrument)
 - GUBM junction boxes serve as an enclosure for meters, gauges and similar devices.
 - Complete with round, explosionproof glass window cover. Permits direct reading of enclosed instrument.
 - Furnished with one 3/4" drilled and tapped entry.
 - Mounting bosses are provided in the bottom of GUBM can be drilled and tapped for fastening of instrument mounting bracket.
- Surface covers furnished with DER and GUB junction boxes have lugs to take a bar or wrench. Other style covers, as listed below, are available.
- Sealing covers have a plugged hole through which the box can be filled with sealing cement after installation. See *Fittings Section* for information regarding sealing cement. Note: When sealing covers are used, splices or taps within the Unilets are prohibited by the CEC.
- Dome covers permit conductors to be pulled in with the ends extending well out beyond box body where splices can easily be made. The splices need not be crowded back into the box, but can be left as is when dome cover is used for their enclosure and protection.

Standard Materials

- Bodies: copperfree (4/10 of 1% max.) aluminum or malleable iron bodies
- DER and GUB covers: copperfree (4/10 of 1% max.) aluminum
- GUBM covers: copperfree (4/10 of 1% max.) aluminum and glass

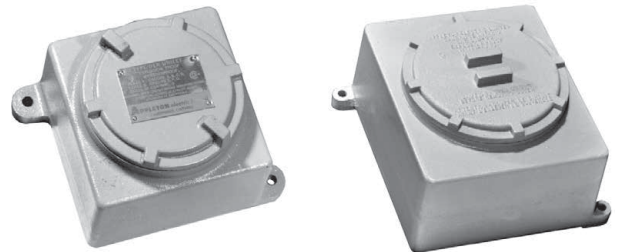

DER1C

GUB2C

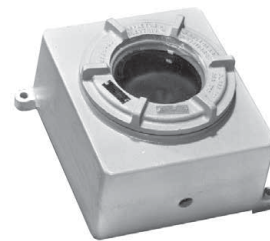

GUBM-2C

Options

- Other hub arrangements and sizes are available. Contact your local representative for details.
- Other means of instrument fastening are available. Contact your local representative for details.
- Instrument mounting plates or brackets can be furnished. On receipt of complete instrument dimensions, prices will be quoted. Contact your local representative for details.
- To order DER1C or DER1CA without mounting lugs add suffix **-LF**.

CEC Certifications and Compliances

- CSA Standard: C22.2 No. 25, C22.2 No. 30
- CSA Certified: 013017

DER, GUB and GUBM Cast Junction Boxes

Explosionproof, Dust-Ignitionproof, Watertight.

Furnished with surface cover and mounting lugs.

CEC:

- Class I, Division 1 and 2, Groups A, B, C, D
- Class I, Zone 1 and 2
- Class II, Division 1 and 2, Groups E, F, G
- Class III, Enclosure 4

ENCLOSURES AND JUNCTION BOXES: NEC/CEC EXPLOSIONPROOF ENCLOSURES

Ordering Information

Determining Catalog Numbers

- To determine the catalog number of junction boxes with entries, the following information should be shown:
 - 1) Junction box catalog number from listings on the following pages
 - 2) Sketch number of hub arrangement selected from the illustration below.
 - 3) Entry symbols taken from the table shown below. Start from the left (at Hub "A") on the top of the junction box and continue in rotation clockwise around its body. Where no entry is required, the symbol X should be inserted. The three various divisions of the catalog number should be separated by dashes.

Example mm (in)

GUB2C junction box is required with threaded conduit entries and unions. The arrangement of entries is per sketch #16.

- A — is to be 50.8 (2.00) drilled and tapped entry
- B — 31.8 (1.25)
- C — Blank (no entry)
- D — 50.8 (2.00)
- E — Blank
- F — 25.4 (1.00)
- J — Blank

The catalog number is:

GUB2C-16-64X6X3X.

Unions are required at B and D.

Order UNY male unions from the Fittings Section of the catalog.

Conduit Entry Symbols

Drilling and Tapped or Threaded Hubs				Union Hubs (GUB4 only)			
Size mm (in)	Symbol	Size mm (in)	Symbol	Size mm (in)	Symbol	Size mm (in)	Symbol
12.7 (0.50)	1	50.8 (2.00)	6	12.7 (0.50)	1E	50.8 (2.00)	6E
19.1 (0.75)	2	63.5 (2.50)	7	19.1 (0.75)	2E	63.5 (2.50)	7E
25.4 (1.00)	3	76.2 (3.00)	8	25.4 (1.00)	3E	76.2 (3.00)	8E
31.8 (1.25)	4	88.9 (3.50)	9	31.8 (1.25)	4E	88.9 (3.50)	9E
38.1 (1.50)	5	101.6 (4.00)	10	38.1 (1.50)	5E	101.6 (4.00)	10E

Appleton®

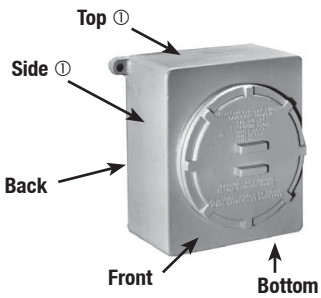
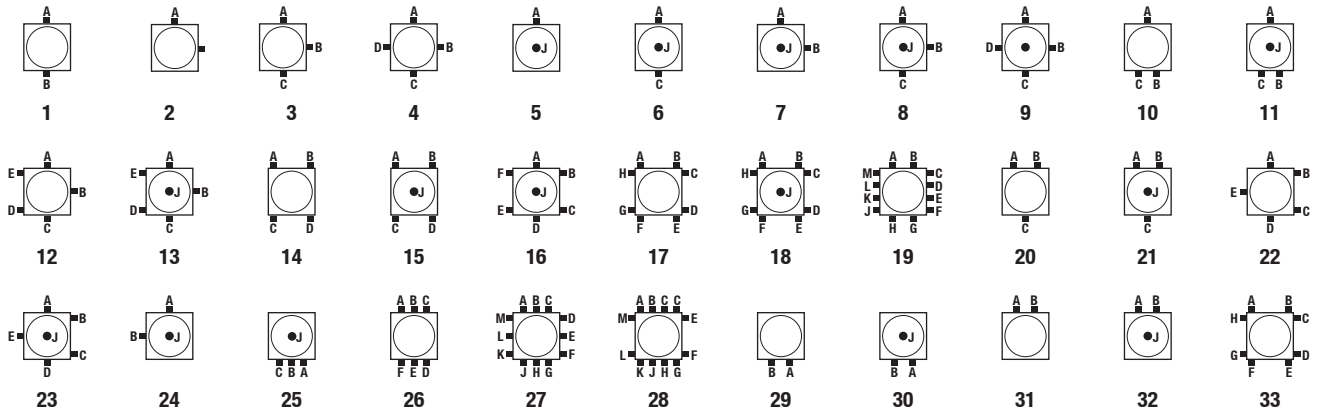

Send sketch and description for other arrangements.

① GUB2C shown. Top and bottom measures 235.0 mm x 139.7 mm (9.25" x 5.25") and sides measure 269.9 mm x 139.7 mm (10.63" x 5.50").

DER, GUB and GUBM Cast Junction Boxes





Explosionproof, Dust-Ignitionproof, Watertight

Furnished with surface cover and mounting lugs.

CEC:

Class I, Division 1 and 2, Groups A, B, C, D
 Class I, Zone 1 and 2
 Class II, Division 1 and 2, Groups E, F, G
 Class III, Enclosure 4

DER and GUB Junction Boxes

		Dimensions in Millimeters (Inches)		Catalog Number	
		Outside	Cover Dia.	Ferrous Alloy	Aluminum
		130.3 x 130.3 x 103.1 (5.13 x 5.13 x 4.06)	98.8 (3.88)	DER1C ①	DER1CA ①
DER1C	GUB1C	177.8 x 177.8 x 165.1 (7.00 x 7.00 x 6.50)	136.7 (5.38)	GUB1C	GUB1CA
		270.0 x 235.0 x 171.5 (10.63 x 9.25 x 6.75)	182.6 (7.19)	GUB2C	GUB2CA
GUB2C	GUB3C	316.0 x 316.0 x 214.4 (12.44 x 12.44 x 8.44)	249.2 (9.81)	GUB3C	GUB3CA

Maximum Size and Number of Entries Supplied on Any One Side

Catalog Number	Dimensions in Millimeters (Inches)									
	12.7 (0.50)	19.1 (0.75)	25.4 (1.00)	31.8 (1.25)	38.1 (1.50)	50.8 (2.00)	63.5 (2.50)	76.2 (3.00)	88.9 (3.50)	101.6 (4.00)

Drilled and Tapped - With Clearance for Conduit Seals

DER1C	3	2	2 ②	1 ②	—	—	—	—	—	—
GUB1C	4	4	4	2	2	1	—	—	—	—
GUB2C	4	4	4	3	3	2	2 ②	—	—	—
GUB3C	4	4	4	3	3	2	2	—	—	—

With UNY Male Unions

DER1C	3	2	2 ②	1 ②	—	—	—	—	—	—
GUB1C	3	3	4	2	2	—	—	—	—	—
GUB2C	4	4	4	3	3	2	1 ②	—	—	—
GUB3C	4	4	4	3	3	2	1	—	—	—

Maximum Entry in Back

GUB1C - 2"; GUB2C - 2"; GUB3C - 6"

① To order DER1C or DER1CA without mounting lugs add the suffix **-LF** to the catalog number.

② Requires pad. Available on special order, contact your local sales representative.

DER, GUB and GUBM Cast Junction Boxes

Explosionproof, Dust-Ignitionproof, Watertight



Furnished with surface cover and mounting lugs.

CEC:

- Class I, Division 1 and 2, Groups A, B, C, D
- Class I, Zone 1 and 2
- Class II, Division 1 and 2, Groups E, F, G
- Class III, Enclosure 4

ENCLOSURES AND JUNCTION BOXES: NEC/CEC EXPLOSIONPROOF ENCLOSURES



GUBM Instrument Junction Boxes

		Type of Body	Mounting Lugs	Hub Size (Inches)	Cover Opening in Millimeters (Inches)	Catalog Number	
						Ferrous Alloy	Aluminum
 GUB-1C	 GUB-2C	GUB-1C	2	3/4	136.5 (5.38)	GUBM-1C	GUBM-1CA
		GUB-2C	2	3/4	188.9 (7.44)	GUBM-2C	GUBM-2CA

DER, GUB and GUBM Junction Box Covers

DER Form 1 and GR Form 2 have the same cover opening.

DER and GUB junction boxes are furnished with surface covers. Order the remaining below listed covers as follows: Specify junction box catalog number and the catalog number of the cover required from the listings below.
 Example: GUB-2-16-64EX63E4EX, except with GUBK-2-6 dome cover.

		Type of Body	Type of Cover	Inside Diameter in Millimeters (Inches)	Catalog Number
	DER1C		Surface Covers	90.5 (3.56)	GRK-2C
	GUB1C			117.5 (4.63)	GUBK-1C
	GUB2C			158.8 (6.25)	GUBK-2C
	GUB3C			225.4 (8.88)	GUBK-3C
	DER1C		Sealing Covers	90.5 (3.56)	GRK-2SC

DER, GUB and GUBM Cast Junction Boxes

Explosionproof, Dust-Ignitionproof, Watertight

Furnished with surface cover and mounting lugs.

CEC:

- Class I, Division 1 and 2, Groups A, B, C, D
- Class I, Zone 1 and 2
- Class II, Division 1 and 2, Groups E, F, G
- Class III, Enclosure 4

GUBM Dimensions in Millimeters (Inches)

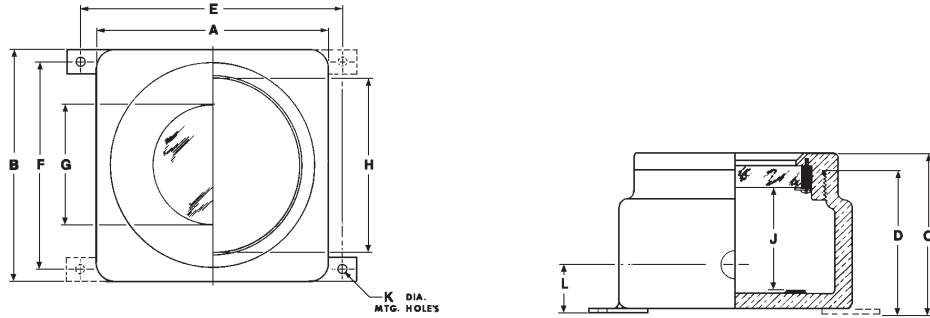

Catalog Number	Mounting Lugs	Dimensions in Millimeters (Inches)										
		A	B	C	D	E	F	G – Dia.	H – Dia.	J	K – Dia.	L
GUBM-1C	2	177.8 (7.00)	177.8 (7.00)	165.1 (6.50)	133.4 (5.25)	209.6 (8.25)	152.4 (6.00)	92.1 (3.63)	136.5 (5.38)	117.5 (4.63)	12.7 (0.50)	52.4 (2.06)
GUBM-2C	2	235.3 (9.27)	269.1 (10.59)	170.7 (6.72)	142.9 (5.63)	263.5 (10.38)	243.4 (9.59)	127.0 (5.00)	185.7 (7.31)	111.1 (4.38)	12.7 (0.50)	52.4 (2.06)

ENCLOSURES AND JUNCTION BOXES: NEC/CEC EXPLOSIONPROOF ENCLOSURES

Appleton®

DER, GUB and GUBM Cast Junction Boxes

Explosionproof, Dust-Ignitionproof, Watertight

Furnished with surface cover and mounting lugs.

CEC:

- Class I, Division 1 and 2, Groups A, B, C, D
- Class I, Zone 1 and 2
- Class II, Division 1 and 2, Groups E, F, G
- Class III, Enclosure 4

ENCLOSURES AND JUNCTION BOXES: NEC/CEC EXPLOSIONPROOF ENCLOSURES

GUB Dimensions in Millimeters (Inches)

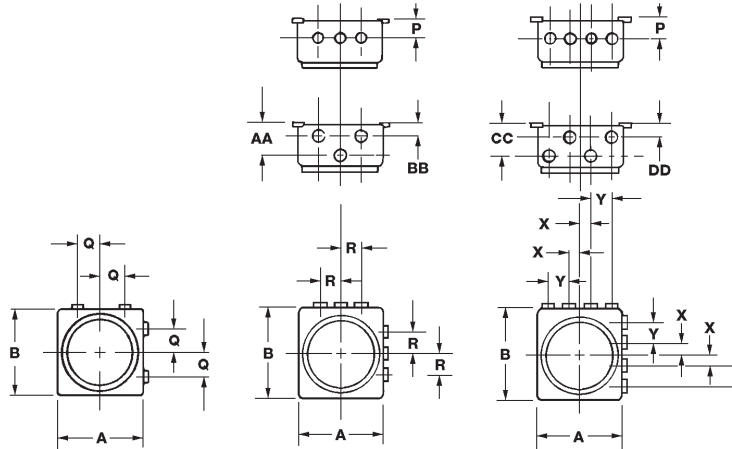

Type	Entry Size	Dimensions in Millimeters (Inches)									
		P	Q	R	X	Y	AA	BB	CC	DD	
Threaded Entries ①	DER1C	1/2	36.5 (1.44)	30.2 (1.19)	36.5 (1.44)	—	—	2	24.6 (0.97)	—	—
		3/4	36.5 (1.44)	30.2 (1.19)	—	—	—	—	—	—	—
		1 ①	36.5 (1.44) ①	30.2 (1.19) ①	—	—	—	—	—	—	—
		1-1/4 ①	36.5 (1.44) ①	—	—	—	—	—	—	—	—
Top or Bottom Side 9-1/4" x 5-1/2"	GUB1C	1/2	52.4 (2.06)	36.5 (1.44)	44.5 (1.75)	17.5 (0.69)	34.9 (1.38)	85.7 (3.38)	44.5 (1.75)	88.9 (3.50)	42.9 (1.69)
		3/4	52.4 (2.06)	36.5 (1.44)	44.5 (1.75)	17.5 (0.69)	34.9 (1.38)	85.7 (3.38)	44.5 (1.75)	88.9 (3.50)	42.9 (1.69)
		1	52.4 (2.06)	36.5 (1.44)	44.5 (1.75)	17.5 (0.69) ③	34.9 (1.38) ③	85.7 (3.38)	44.5 (1.75)	88.9 (3.50) ③	42.9 (1.69) ③
		1-1/4	52.4 (2.06)	36.5 (1.44)	—	—	—	—	—	—	—
		1-1/2	52.4 (2.06)	—	—	—	—	—	—	—	—
		2	63.5 (2.50)	—	—	—	—	—	—	—	—
		2-1/2 ①	66.8 (2.63) ①	57.2 (2.25) ①	—	—	—	—	—	—	—
Top or Bottom Side 9-1/4" x 5-1/2"	GUB2C	1/2	52.4 (2.06)	52.4 (2.06)	71.4 (2.81)	254 (1.00)	50.8 (2.00)	84.1 (3.31)	50.8 (2.00)	90.5 (3.56)	95.3 (3.75)
		3/4	52.4 (2.06)	52.4 (2.06)	71.4 (2.81)	254 (1.00)	50.8 (2.00)	84.1 (3.31)	50.8 (2.00)	90.5 (3.56)	95.3 (3.75)
		1	52.4 (2.06)	52.4 (2.06)	71.4 (2.81)	254 (1.00)	50.8 (2.00)	84.1 (3.31)	50.8 (2.00)	90.5 (3.56)	95.3 (3.75)
		1-1/4	52.4 (2.06)	52.4 (2.06)	71.4 (2.81)	—	—	84.1 (3.31)	50.8 (2.00)	—	—
		1-1/2	52.4 (2.06)	52.4 (2.06)	71.4 (2.81) ③	—	—	84.1 (3.31) ③	50.8 (2.00) ③	—	—
		2	66.8 (2.63)	57.2 (2.25)	—	—	—	—	—	—	—
		2-1/2 ①	66.8 (2.63) ①	57.2 (2.25) ①	—	—	—	—	—	—	—
Top or Bottom Side 9-1/4" x 5-1/2"	GUB3C	1/2	82.6 (3.25)	60.3 (2.38)	82.6 (3.25)	30.2 (1.19)	60.3 (2.38)	98.4 (3.88)	68.3 (2.69)	68.3 (2.69)	98.4 (3.88)
		3/4	82.6 (3.25)	60.3 (2.38)	82.6 (3.25)	30.2 (1.19)	60.3 (2.38)	98.4 (3.88)	68.3 (2.69)	68.3 (2.69)	98.4 (3.88)
		1	82.6 (3.25)	60.3 (2.38)	82.6 (3.25)	30.2 (1.19)	60.3 (2.38)	98.4 (3.88)	68.3 (2.69)	68.3 (2.69)	98.4 (3.88)
		1-1/4	82.6 (3.25)	60.3 (2.38)	82.6 (3.25)	—	—	98.4 (3.88)	68.3 (2.69)	—	—
		1-1/2	82.6 (3.25)	60.3 (2.38)	82.6 (3.25)	—	—	98.4 (3.88)	68.3 (2.69)	—	—
		2	82.6 (3.25)	60.3 (2.38)	—	—	—	—	—	—	—
		2-1/2	82.6 (3.25)	60.3 (2.38) ①	—	—	—	—	—	—	—
Left or Right Side 10-5/8" x 5-1/2"	GUB2C	1/2	52.4 (2.06)	52.4 (2.06)	71.4 (2.81)	254 (1.00)	50.8 (2.00)	84.1 (3.31)	50.8 (2.00)	90.5 (3.56)	44.5 (1.75)
		3/4	52.4 (2.06)	52.4 (2.06)	71.4 (2.81)	254 (1.00)	50.8 (2.00)	84.1 (3.31)	50.8 (2.00)	90.5 (3.56)	44.5 (1.75)
		1	52.4 (2.06)	52.4 (2.06)	71.4 (2.81)	254 (1.00)	50.8 (2.00)	84.1 (3.31)	50.8 (2.00)	90.5 (3.56)	44.5 (1.75)
		1-1/4	52.4 (2.06)	52.4 (2.06)	71.4 (2.81)	30.2 (1.19) ④	58.7 (2.31) ④	84.1 (3.31)	50.8 (2.00)	87.3 (3.44) ④	47.6 (0.88) ④
		1-1/2	52.4 (2.06)	52.4 (2.06)	79.4 (3.13)	—	—	84.1 (3.31)	50.8 (2.00)	—	—
		2	66.8 (2.63)	57.2 (2.25)	—	—	—	—	—	—	—
		2-1/2 ①	66.8 (2.63) ①	57.2 (2.25) ①	—	—	—	—	—	—	—

Caution: Dimensions between hub centres are for use with hubs of the same size. These dimensions will not necessarily hold true for a combination of hubs of extreme sizes. Please consult Engineering Dept. for special combinations of hubs.

① Dimensions permit assembly of seals on adjacent conduit runs.

② Requires pad. Available only on special order from factory.

③ Seals must be staggered for assembly on adjacent conduit runs.

④ Dimensions will not permit assembly of unions on adjacent conduit runs.